

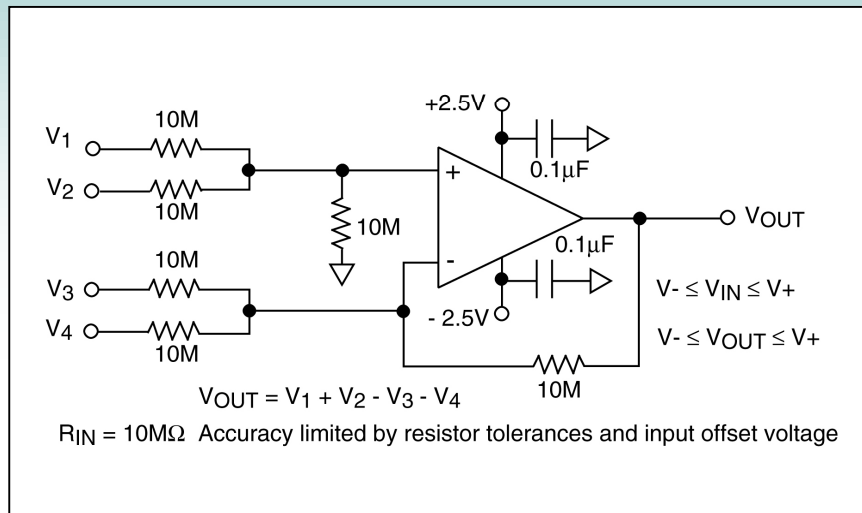

High Input Impedance Precision DC Summing Amplifier



Description

This circuit presents a simple precision DC summing amplifier that has high input impedance of 10Mohm. The obvious advantage is that the 10Mohm high input resistance of the summing resistor(s) reduces the loading on the input signal sources and therefore affords better signal accuracy and integrity. The input leakage currents to the operational amplifier must be significantly lower than the lowest input signal currents available so that the accuracy of the summing amplifier is preserved. In this example, a 10Mohm resistor is used as a basic summing amplifier input resistor. To determine an input signal resolution, assume a "signal current" available as equal to 10pA, which computes to 10Mohm x 10pA = 100μV. The input leakage current of the operational amplifier therefore limits the input voltage resolution and the minimum discernable voltage signal. A CMOS operational amplifier with very low input-leakage current specifications guaranteed would be required for this type of application. The input offset voltage of the operational amplifier would also cause an error in the output of the summing amplifier. Select an operational amplifier that has both very low input leakage currents and very low input offset voltages for this circuit. This type of operational amplifier is known as a low input signal power ($V_{IN} \times I_{IN}$) operational amplifier.

Recommended Components

ALD1721, ALD1726, ALD1712, ALD1722
 ½ ALD2711, ½ ALD2711, ½ ALD2726, ½ ALD2722, ½ ALD2724

Other Related Circuit Ideas

Schematic no. amp_27001.0 High Input Impedance DC Summing Amplifier
 Schematic no. amp_27002.0 Low Voltage High Input Impedance Precision DC Summing Amplifier