

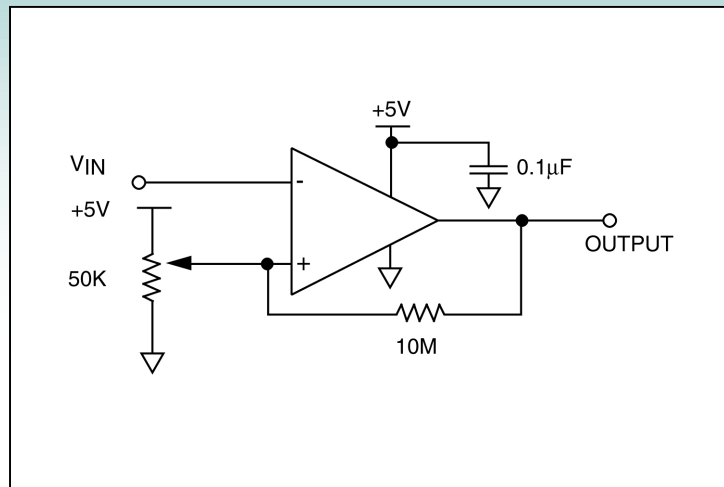

Rail-to-Rail Voltage Comparator



Description

This circuit utilizes a rail-to-rail operational amplifier with high slew rate to act as a rail-to-rail voltage comparator. The input reference level is adjusted from V+ rail to ground via a single potentiometer. Note that this input reference level is ratiometric with the supply voltage. Alternatively, this potentiometer can be replaced with any fixed reference signal generated externally. The output changes state whenever the input signal V_{IN} at the -input terminal crosses the reference voltage at the +input terminal. A high-precision voltage comparator function can be implemented by selecting a low offset voltage rail-to-rail operational amplifier. Start this component selection process by first determining the available voltage supplies, the comparator response time and the offset voltages required. This selection process can then be narrowed down to selecting an operational amplifier with very high input impedance (a few pA input currents), such that the input of the operational amplifier would not load down even a high-valued potentiometer; and the power consumption of the operational amplifier itself. The input characteristics of the operational amplifier would limit the resistor and potentiometer values that can be used. For micropower applications a high value for the potentiometer and a low power consuming operational amplifier such as the ALD1706 could be used.

Recommended Components

ALD1701, ALD1702, ALD1706, ALD1712, ALD4702

Other Related Circuit Ideas

[Schematic no. cd_23008.0 Rail-to-Rail Voltage Comparator](#)

[Schematic no. cd_23009.0 Rail-to-Rail Window Comparator](#)

[Schematic no. cd_23010.0 Voltage Comparator with Complementary Outputs](#)