

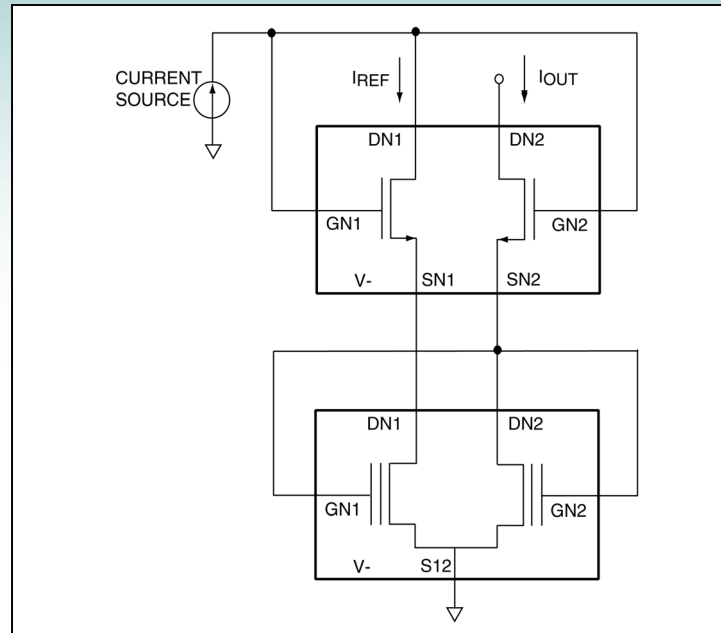

High Output Impedance Current Source



Description

This current source uses a reference current and produces an output current that has substantially higher dynamic output impedance, particularly for low current levels of less than 100uA. This current source buffers the reference current and produces a constant current for a wide voltage range. This current source utilizes two pairs of N channel matched pair MOSFETs connected in a cascode configuration. The bottom MOSFET pair must be a matched pair and the top MOSFET pair must also be a matched pair. However, the top pair and the bottom pair do not have to be the same model. The lower voltage compliance range is determined by the $2 \times V_{GS(TH)}$ and the upper voltage compliance voltage are by breakdown voltage. Use very low $V_{GS(TH)}$ devices such as ALD110802 and ALD110800 to reduce the lower voltage compliance limit.

Recommended Components

ALD110902 + ALD1116, 2 x ALD1102, 1/2 ALD1103 + ALD1102

Other Related Circuit Ideas

[Schematic no. cs_11002.0 Cascode Current Source](#)

[Schematic no. cs_11008.0 High Output Impedance Current Mirror](#)