

**Differential EPAD® MOSFET Matched-Pair Circuit with Summing Output**

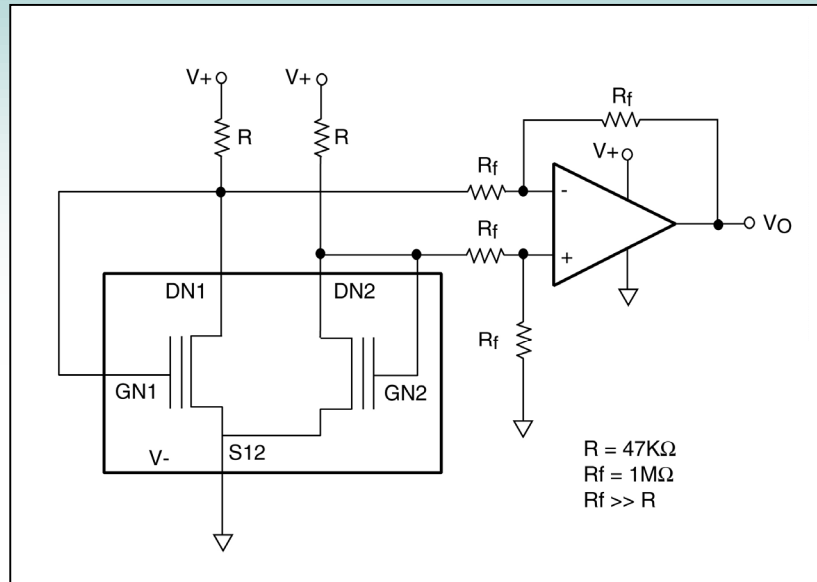

**Description**

The matched pair EPAD MOSFET Array provides two separate, matched outputs at DN1 and DN2. Each output could be biased to provide the same type of output characteristics. For example, both outputs can be designed to provide the same matched, temperature coefficient. Or, one output DN1 can be biased to give a different temperature coefficient from DN2. The two outputs are then summed through a summing amplifier to give a single output  $V_o$ . By careful design of bias voltages and selection of components, this circuit can yield a wide range of desired temperature characteristics of its output,  $V_o$ .

**Recommended Components**

¼ ALD1108E, ½ ALD110908, or any of the EPAD MOSFETs  
ALD1712, ALD1721, ALD1722, ALD1726

**Other Related Circuit Ideas**

[Schematic no. fet\\_11111.0](#) Amplify and Shift EPAD MOSFET Output with an Operational Amplifier

[Schematic no. fet\\_11110.0](#) Select  $V_o$  by Using EPAD Transistor and Resistor Ratios

[Schematic no. fet\\_11113.0](#) Differential EPAD MOSFET Matched-Pair Circuit with Buffered and Summed Outputs