

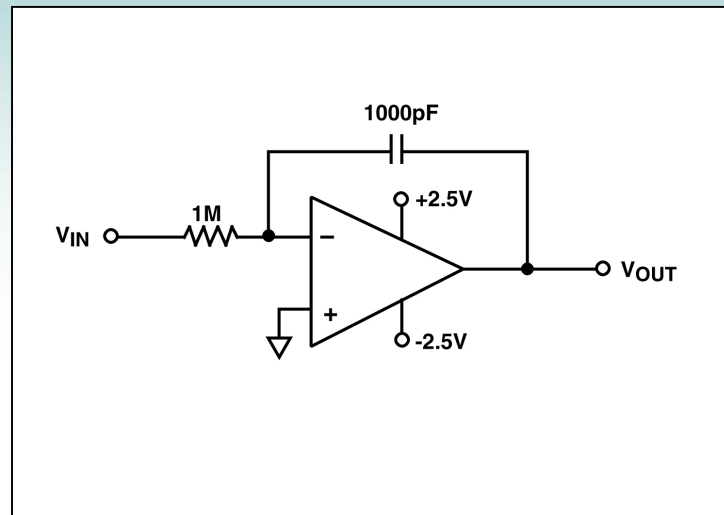

Charge Integrator



Description

This circuit is a basic integrator circuit. The integration current through the 1M Ω resistor is produced by input V_{IN} and is directly proportional to V_{IN} , given by $I = V_{IN}/1M\Omega = V_{IN} \mu A$. The integration capacitor C (1000pF) is charged with this integration current. Assuming there is no loss of charge at the negative input terminal of the integrator amplifier, the time required in charging the integrating capacitor depends directly on the magnitude of $1/V_{IN}$ and is proportional to the product of R and C (equal to 1M Ω x 1000pF). For longer integration time, increase the value of C proportional to the amount of time increase in order to prevent output voltage saturation. Selection of capacitor C with low internal leakage current will help to minimize integrator time constant variation. Note that this integrator circuit may require additional circuitry to either reset the output voltage or limit the output to a certain range to prevent it from eventually becoming saturated at one of the supply rails. Selection of the operational amplifier requires a) extremely low input leakage current b) low input offset voltage c) sufficient slew rate and output current to be able to charge the capacitor.

Recommended Components

ALD1706, ALD1701, ALD1702, ALD1704, ALD2701, ALD2702, ALD2704, ALD2706, ALD2711

Other Related Circuit Ideas

[Schematic no. int_42005.0 Precision Charge Integrator](#)

[Schematic no. int_42002.0 Differential Integrator with Frequency Controlled Gain](#)