

Ultra Long Time Constant Integrator

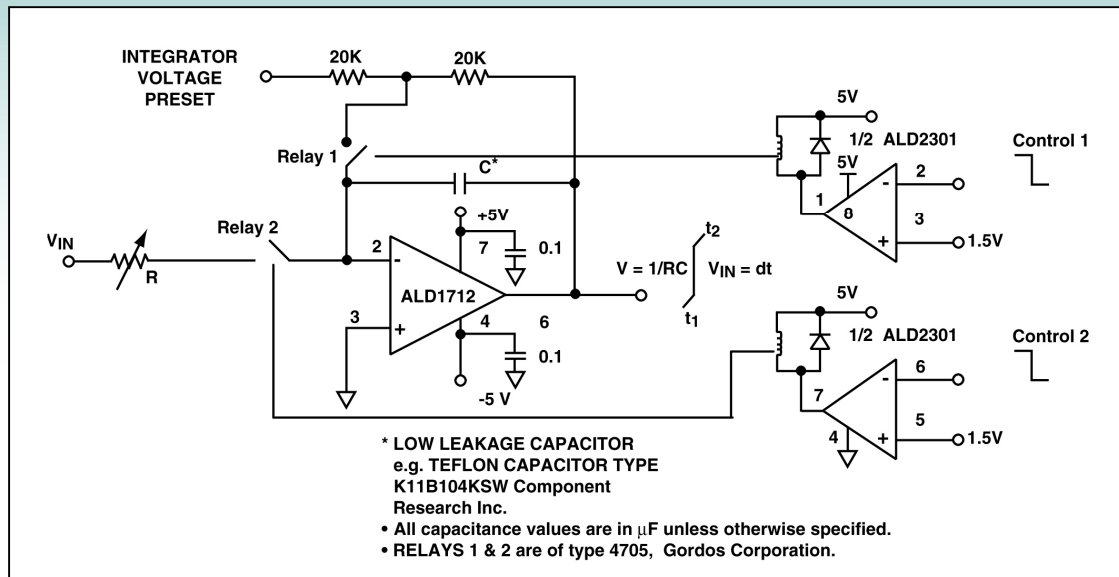

Description

This circuit is a complete ultra long time-constant charge integrator circuit. The integration current I_{IN} is produced by input V_{IN} and is directly proportional to V_{IN} , given by $I_{IN} = V_{IN}/R$. The feedback integration capacitor C is charged with this integration current. Assuming there is no loss of charge at the negative input terminal of the integrator amplifier, the time required in charging the integrating capacitor depends directly on the magnitude of $1/V_{IN}$ and is proportional to the product of R and C . This integrator circuit utilizes 2 separate relays to control the integration and the reset cycles. Initially, at the beginning of a charge cycle, Relay 1 is closed to preset the negative input to the operational amplifier to a preset voltage. When sufficient time has been allowed for the preset voltage to charge the integrating capacitor C , Relay 1 is opened. Then Relay 2 is closed to start the integration cycle. In order to generate ultra long time-constant, select a large value for both R and C . Select a large value for R consistent with leakage currents permitted on the printed circuit board, and select large value for C based on size, cost and internal leakage specification requirements. Key selection criteria for an operational amplifier are a) extremely low input leakage currents b) low input offset voltage c) sufficient slew rate and output current to charge the capacitor for the time-constant desired.

Recommended Components

ALD1712, ALD1721, ALD1722, ALD2711, ALD2722, ALD2726

Other Related Circuit Ideas

Schematic no. int_42002.0 Differential Integrator with Frequency Controlled Gain