

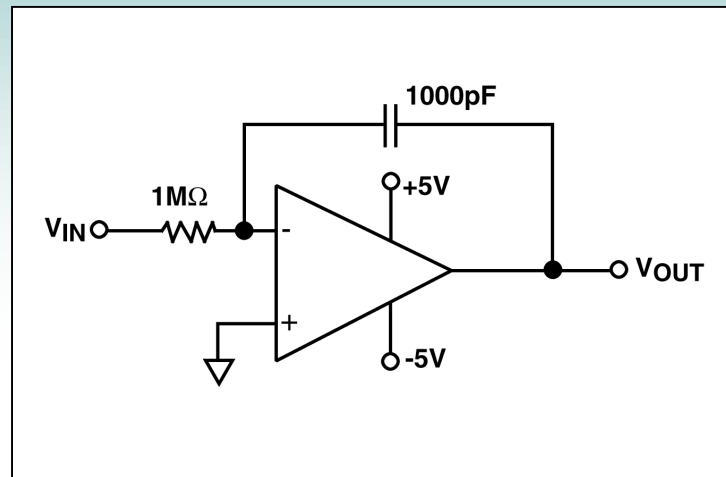

Precision Charge Integrator



Description

This circuit is a basic integrator circuit. The integration current I_{IN} through the 1MΩ resistor is produced by input V_{IN} and is directly proportional to V_{IN} , given by $I_{IN} = V_{IN}/1M\Omega = V_{IN} \mu A$. The feedback integration capacitor C (1000pF) is charged with I_{IN} . Assuming no loss of charge at the negative input terminal of the integrator amplifier, the time required in charging the integrating capacitor depends directly on the magnitude of $1/V_{IN}$ and is proportional to the product of R and C (equal to 1MΩ x 1000pF). For longer integration time, increase the value of R and C proportional to the amount of time increase. Selection of capacitor C with low internal leakage current will help to minimize integrator time constant variation. Note that this integrator circuit may require additional circuitry to either reset the output voltage or limit the output to a certain range to prevent it from eventually becoming saturated at one of the supply rails. Precision in this integrator is achieved by careful selection of all the various components as follows:

- A. An operational amplifier with a) extremely low input leakage current b) low input offset voltage c) sufficient slew rate and output current to be able to charge the capacitor.
- B. A very low leakage analog switch with minimal extraneous charge injection
- C. A very low leakage and precision value capacitor, such as polyester or polypropylene types
- D. Precision and temperature stable resistor.

Recommended Components

ALD1721; ALD1722; ALD1704A; ALD1726

Other Related Circuit Ideas

Schematic no. int_42002.0 Differential Integrator with Frequency Controlled Gain

Schematic no. int_42003.0 Ultra Long Time Constant Integrator