

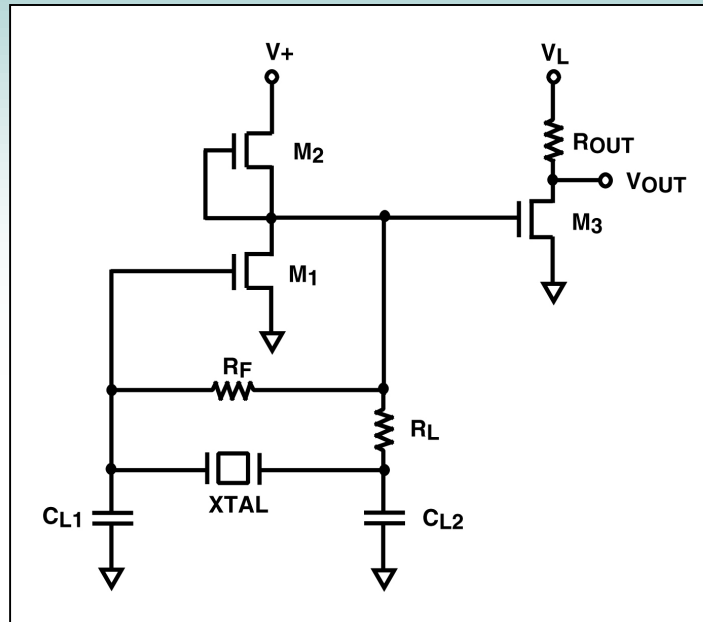

**0.5V Crystal Oscillator Circuit with Output Buffer**



**Description**

This is an ultra low-voltage crystal oscillator circuit using EPAD MOSFETs with active load and output buffer operating on a single 0.5V power supply, which results in ultra low power consumption. This circuit is the similar to a standard crystal oscillator circuit in 5V circuits. Active loads used in a crystal oscillator circuit tend to provide wider functional V+ ranges for a select set of components.

Circuit performance Data: V+=0.5V, I+= 64μA, PD=32μW, Crystal frequency = 4 MHz.

VL is an output voltage level that can be equal to, higher than or lower than V+, depending on desired output voltage swing levels. Rout must be selected for a chosen VL to provide desired voltage swing and minimum current drain. An example: VL= 0.5V, IL= 60μA, PD= 30μW, VOH=413mV, VOL=171mV.

At higher crystal frequencies in excess of 4 MHz, a dual EPAD MOSFET can be connected in parallel to provide more low voltage drive current necessary. The output buffer is powered by VL using pull up resistor ROUT. Rout value can be optimized to give desired output voltage swing levels, to provide adequate output drive currents, and to minimize power consumption.

**Recommended Components**

EPAD MOSFETs: M1 ALD110800/ ALD110900 (single or dual MOSFET connected in parallel); M2, M3: ½ ALD114904; CL1=10pF; CL2 = 22pF; RF= 5.6MOhm; RL= 6 Ohm; ROUT = 2.4KOhm

**Other Related Circuit Ideas**

Schematic no. osc\_42006.0 0.3V Crystal Oscillator Circuit with Buffered Output