

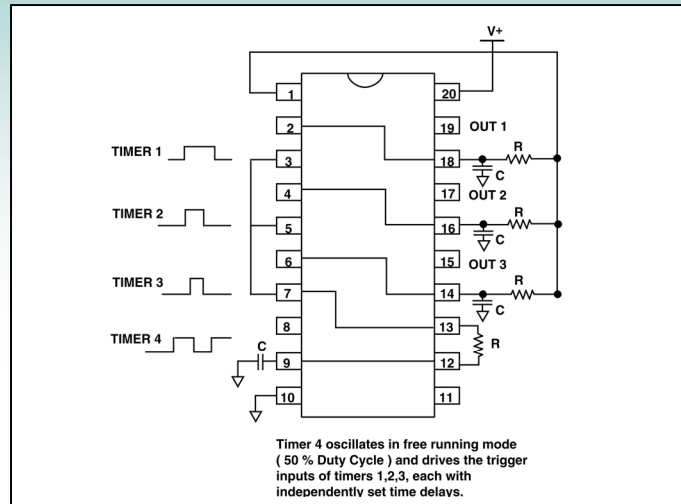

Synchronized Timing Generators



Description

This circuit is configured as a synchronized timing generator. The single chip quad 555 type timer offer excellent timing and temperature tracking between the 4 separate timers and is ideal for generating three synchronized time delay pulses that track each others' timing. In this circuit, timer 4 operates as a free running oscillator. Timers 1, 2 and 3 are independent time delay generators, each triggered by the same clock from timer4 and operate as a monostable one-shot circuit. The monostable circuit generates one fixed delay pulse every time it is triggered. In the initial state, the circuit is in the standby mode. The trigger input is at a high level, and the output is at a low voltage level. The Discharge output at pin2 (pins 4 and 6 for the other 2 monostable circuits respectively) is on LOW, and that clamps the capacitor C to ground potential. When a negative going trigger pulse is delivered to input pin3 (pins5 and 7 respectively), the flip-flop inside the 555 timer is set to turn off the Discharge transistor at pin2 and the RC network starts charging towards V+, with a time constant equal to $R \times C$. Capacitor C is charged towards $2/3 V+$ and when its voltage reaches that threshold level, the output driver on pin19 (pins 17 and 15 respectively) and the Discharge transistor at pin2 is also turned on, discharging C once again. The time constant of the pulse width is determined by $t = 1.1 R \times C$, which is the time it takes for the capacitor to charge from 0 to $2/3 V+$. This circuit only respond to negative going pulses. Once triggered, the output will remain HIGH until the time delay has elapsed, even if it is triggered again during this time interval. Using CMOS quad 555 timer circuits, a very wide timing range at very low level of voltage spikes and power dissipation can be achieved. Selection of the values of R is limited by the input leakage specifications of the timer at pin2 and pin18. R resistor values are also limited by the internal leakage current at the capacitor C. C usually has a range from 10,000 μ F down to 0.

Recommended Components

ALD4501

Other Related Circuit Ideas

Schematic no. time_15005.0 Quad Monostable Mode Operation (One Shot Pulse)

Schematic no. time_15004.0 Quad Astable Mode Operation (Free Running Oscillator)

©2005 Advanced Linear Devices, Inc. Information furnished by Advanced Linear Devices, Inc. (ALD) is believed to be accurate and reliable. However, ALD assumes no responsibility for the use of such information nor for any infringement of patent or rights of third parties that may result from its use. No license is granted implication or otherwise under any patent rights of ALD.